

1.1.2.7 High Power Thermal Sensors

1.1.2.7.4 Very High Power Water Cooled Thermal Sensors

100W to 120kW

Features

- Highest powers
- Water cooled
- Up to 120kW
- Ø200mm aperture

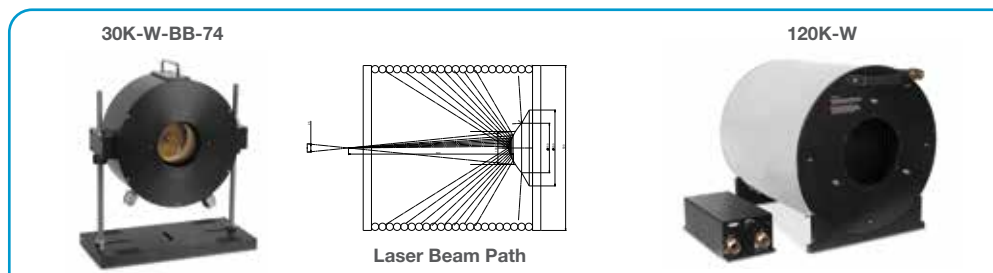

Model	30K-W-BB-74	120K-W
Use	High power up to 30kW	Measuring Highest powers to 120kW
Measurement Type	Beam deflector + broadband absorber	Water cooled beam absorber chamber with deflecting cone. Separate power measuring unit monitoring input and output cooling water flow and temperature
Spectral Range μm	0.8 - 2	0.9 - 1.1 ^(a)
Aperture mm	Ø74mm	Ø200
Power Range for Calibrated Reading	100W - 30kW	10kW - 120kW
Power Noise Level	1W	$\pm 20\text{W}$ with stable water temperature
Backscattered Power	$\sim 4.3\%$ without Scatter Shield, $\sim 1.3\%$ with Scatter Shield ^(b, c)	Less than 1%
Maximum Average Power Density kW/cm ²	10kW/cm ² anywhere in the beam	Designed for near Gaussian beam. The $1/e^2$ beam diameter should have a divergence of 0 to 6 degrees and should be Ø100mm in diameter at the reflecting cone (see sketch above where the beam may also be collimated and not divergent as long as beam diameter requirement is met).
Beam Centering Requirements IMPROPERLY CENTERED BEAM CAN CAUSE DAMAGE TO SENSOR	For circular beam centered within $\frac{1}{4}$ of beam diameter. Maximum tilt angle ± 5 degrees. For rectangular beam please consult Ophir representative	Beam to be centered on deflecting cone $\pm 5\text{mm}$ and parallel ± 2 degrees
Response Time 0-95% typ	7s	40s at flow rate 60 liter/min and 60s at flow rate 20 liter/min
Calibration Uncertainty $\pm\%$	1.9	1.9
Power Accuracy $\pm\%$	5 ^(a)	5 ^(a)
Linearity with Power $\pm\%$	2	2
Variation with Beam Size $\pm\%$	1 from 20 to 40 mm 1.5 from 15 to 20 mm and 40 to 45 mm	NA
Cooling Requirements	25 liter/min at full power, proportionally less at lower power. Min flow rate 6 liter/min. Water temperature range 15-30°C. Water temperature rate of change $< 1^\circ\text{C}/\text{min}$ ^(d)	Water flow rate, 60 liters/min at max power. Inlet temperature 15-20degC. Inlet water temperature rate of change $< 0.3^\circ\text{C}/\text{min}$ at full power, proportionately less at lower power ^(b, c)
Water Pressure Drop across Beam Absorber	Pressure drop across sensor $\sim 0.2\text{MPa}$. Pressure drop across 8 meters of $\frac{1}{2}$ " tubing with 9.5mm ID is $\sim 0.3\text{MPa}$	0.4MPa at 60 liter/min flow rate
Water Connections	Quick connector for $\frac{1}{2}$ " OD nylon tubing ^(c)	Up to 4 meters in each direction of 1" OD 13/16" ID flexible nylon tubing
Outputs	10 meter cable terminated in DB15 smart connector	1. Cable terminated in DB9 plug with RS232 ASCII output reading power, flow rate and temperature on PC (using WaterFlowMeter PC App). Cable lengths 10 meters (recommended for access to full data). 2. Cable terminated in DB15 Ophir smart plug reading power.
Optional Accessories ^(c)	30K-W Scatter Shield (P/N 7Z08293) 30K-W Rubber Feet Assembly (P/N 7Z08217)	NA
Dimensions	See drawing on next page	See drawing on next page
Weight kg	19	Beam Absorber 50kg. Power measuring unit 10kg
Compliance	CE, UKCA, China RoHS	CE, UKCA, China RoHS
Version	V4	
Part number	7Z07136	7Z02691
Note: (a)	Calibrated at 1.07 μm . For other wavelengths in the ranges of 0.8 - 0.95 μm & 1.1 - 2 μm add up to $\pm 2\%$ to the calibration error	Calibrated for 1.07 μm
Note: (b)	When scatter shield is installed, use the 107S laser setting to compensate for the slightly higher reading. When not installed, use the 107 setting	Minimum flow rate should not be below 20 liter/min. It is recommended that the user install a safety interlock flow switch on the return water line (after beam dump) to immediately shut down the laser if flow rate drops
Note: (c)	For further information and options see Accessories for High Power Sensors on pages 97-100	For solutions for prolonged usage with untreated water (tap water, non DI water), please contact Ophir
Note: (d)	For solutions for prolonged usage with untreated water (tap water, non DI water), please contact Ophir	

* For drawings please see page 90

30K-W-BB-74

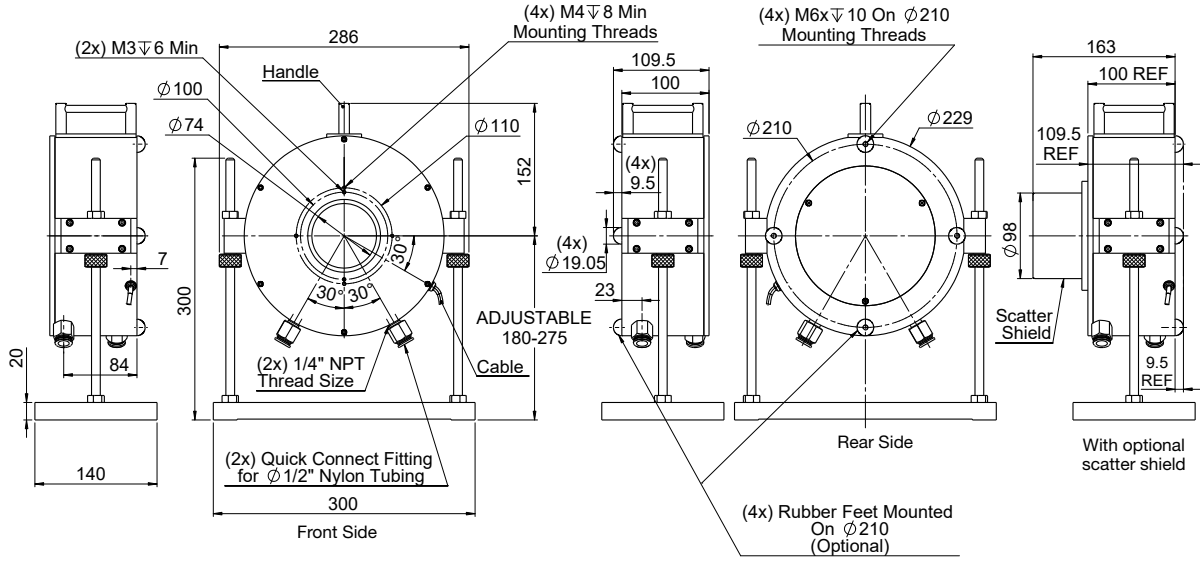

120K-W

